

feeder pillar for power

PETRA E IX/4



- dimensions: 1.10m/ \varnothing 406mm/ door: 900mm
- shape: round tube
- finish: - hot-dip galvanised steel, powder coated in RAL or DB colour
- stainless steel V2A (304), brushed and passivated
- door: - door with hinges
- with cable slot
- with tri-head bolt lock M6, incl. 1 tri-head bolt key M6
- equipment: - solid rubber distributor inside, IP 44, completely wired
- door down: equipment for water
- C-rail with installation bridge
- tube with earth stud
- use: operates with closed access door, while using socket(s) only and CEE socket(s) 16A or 32A and operates with open access door, while using (also) the CEE socket 63A
- installation: with welded flange plate to be screwed
- accessories: - excl. bolt-on root (G510D/600) with screws
- excl. accessory ring (Z519) to cover the fixing screws
- application areas: vandalism resistant feeder pillar for public and private areas, such as e.g. markets, camping sites, festivals, squares, hotels, churches, cemeteries, schools, hospitals, town halls, home for elderly people, factory premises or marinas

equipment	kg	product code
-----------	----	--------------

- | | | |
|--|--|--|
| 4 pcs. sockets 16A / 250V | | |
| 1 pc. CEE socket 16A / 5p / 400V | | |
| 1 pc. CEE socket 32A / 5p / 400V | | |
| 1 pc. CEE socket 63A / 5p / 400V | | |
| 4 pcs. miniature circuit breakers 16A / 1p-C | | |
| 1 pc. miniature circuit breaker 16A / 3p-C | | |
| 1 pc. miniature circuit breakers 32A / 3p-C | | |
| 1 pc. miniature circuit breakers 63A / 3p-C | | |
| 1 pc. residual-current circuit breaker 63A / 4 / 0.03A for all 16A and 32A outlets | | |
| 1 pc. residual-current circuit breaker 63A / 4 / 0.03A for 63A outlet | | |
| 1 pc. terminal clamp for max. 5 x 25mm ² | | |
| 1 pc. cable gland M40 (\varnothing 22-32mm) | | |

- | | | |
|--|------|------------------------|
| made of hot-dip galvanised steel, powder coated | 91.0 | 9.946.1004.114SC1C3C6F |
| made of stainless steel, brushed and passivated | 91.0 | 9.946.1004.314SC1C3C6F |

- accessory:**
- | | | |
|--|------|----------------|
| bolt-on root – hot-dip galvanised steel, incl. screws | | |
| G510D/600 | 24.2 | 9.900.0027.011 |
| accessory ring – stainless steel, powder coated | | |
| Z519 | 1.0 | 9.900.0008.49 |
| accessory ring – stainless steel, brushed and passivated | | |
| Z519 | 1.0 | 9.900.0008.53 |

Technical specifications are subject to change without notice. 07.2021

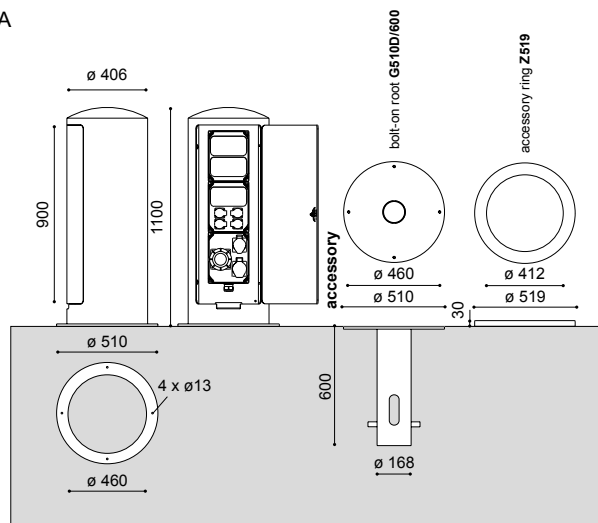

Caution!

While using the plugs and sockets out in the open air a residual current protective device (main isolator) is required according to VDE 0100. The delivered feeder pillars are normally equipped with a main isolator. In that case please take care that the protective device of the main matches with the isolator of the feeder pillar.